

OPERATING INSTRUCTIONS

MODEL 4 & 6 NAMEPLATE DETAIL PRESSES

EASY FIVE-STEP OPERATION

1. Center the Nameplate on the table. Press the clamp handle down to slide the nameplate into a new position. Release the clamp handle to lock it in place. The clamp is fastened to a sliding square (table gauge), which is tightened by means of a small thumb screw. The entire table can be indexed by pressing the space button at the front of the unit.

CAUTION: When indexing the table, be sure to grasp the table lightly with your left hand; the table operates like a typewriter carriage and damage will result if it is allowed to slam against the limit screw.

2. Spin the character dial to select the desired number or letter.

3. Set marking depth by turning the depth adjustment screw. First, set depth until dial contacts the nameplate. Then remove the plate and make another 1-1/2 counter clockwise turn to indent the plate. Turning the screw clockwise makes the impression shallower.

4. Move operating handle forward firmly to make impressions. If the mark is not deep enough, adjust the depth setting. The handle will return to its original position, which automatically indexes the table one notch to the left, placing the nameplate in position for the next character. Move the handle forward or backward halfway to leave a blank space or a space between words.

CAUTION: Forcing the operating handle down or back will cause damage to the machine.

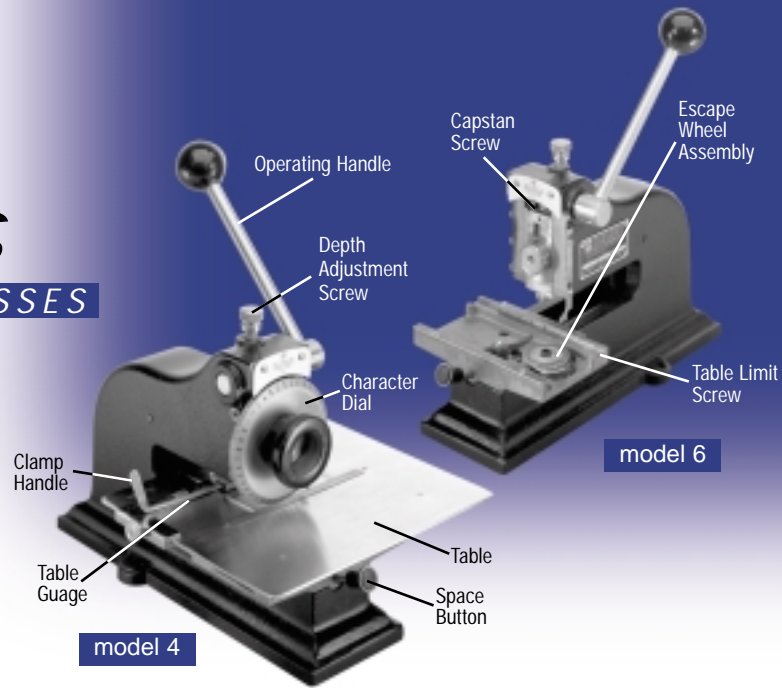

Operating Flexibility. Your Schmidt Nameplate Detail Press can be operated efficiently by pulling the operating handle from a sitting position or by pushing the operating handle for a standing position. Just remember to bring the operating handle to the neutral position -- and not beyond.

To set the plate for stamping a new line of another panel, simply move the table gauge forward or back to center the locating pointer. For added flexibility, the table gauge can be placed on the right edge of the table. The clamp is then in front of the dial and plates are gripped at the bottom, allowing the machine to stamp at the extreme top edge. With the gauge in this position, the throat capacity is also increased to 4.5 inches.

Changing the Character Dial

1. Remove screw in the center of the dial and take off dial, knob and pointer. Place new dial and pointer in position and tighten into place with retaining screw.
2. Slide table to extreme right and remove table limit screw. Return table to left to expose spacing mechanism. Remove escapement wheel and replace with new ones that match new dial size. Replace the limit screw.
3. Return table to marking position.

Extra Dials

All Dial Assemblies are interchangeable and include Knob, Pointer and Escapement Wheel. Sizes available include: 1/16", 3/32", 1/8", 3/16", and 1/4".



SCHMIDT
SERVING YOUR MARKING NEEDS SINCE 1895

(800) 323-1332 • (847) 647-7117

www.gtschmidt.com

PARTS LIST

MODEL 4&6 NAMEPLATE DETAIL PRESSES

Diagram	Part No.	Name
2-24	33020	Space Button Assembly
3	33022	Front Guide
4-21-41	33023	Table Slide Assembly
5	33025	Table - Model 4
5A	33026	Table - Model 5
6	33027	Rear Guide
8	54791	Spring Clamp
10	33031	Stop Arm
11-12-7-38	33033	Pawl Assembly
*13-14		Escapement Wheel Assembly
15	33045	Safety Spring
16	33147	Crank Spring
17	33046	Bell Crank 4
17A	33047	Bell Crank 6
18-45		Dials -- See Notes Below
19	33058	Table Spring - Model 4
19A	33059	Table Spring - Model 6
20	33060	Spacing Rack
22	33062	Drum Gear
23	33063	Ball Spring
25		Pointer
26	33072	Nameplate

Diagram	Part No.	Name
27	33073	Gib
28	33074	Ram with Ball Spring
29	33076	Anvil
30	33077	Capstan Screw
31	33078	Cam
32-33	33079	
	& 48539	Handle & Assembly
34	33080	Trigger Spring
35	33081	Washer
36	33082	Connector Link
37	33084	Gauge Lock
38	33085	Pawl Spring
39-44	33086	Depth Adjustment Screw
40	33088	Clamp Handle
42	33090	Table Gauge Bar
43	33091	Table Gauge Nut
45	33092	Dial Knob
46	33093	Plunger Spring
62	54082	Truarc Ring
41-73	33097	Table Gauger Assembly

*Must have character dial size when ordering

Extra dials

1/16, 3/32 or 1/8
3/16 Dial Assembly
1/4 Dial Assembly

All dial assemblies are interchangeable and include: knob, pointer and an escapement wheel.
\$25.00 minimum order.
\$10 handling fee with each order unless it is ordered online through the website:
www.gtschmidt.com

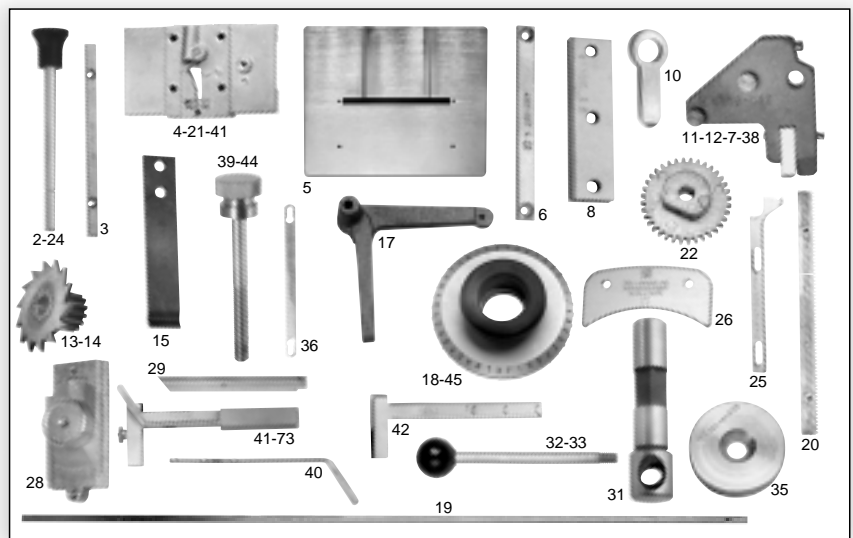

SCHMIDT
SERVING YOUR MARKING NEEDS SINCE 1895

6151 W. Howard Street
Niles, IL 60714-3488
(800) 323-1332
(847) 647-7117
Fax (847) 647-7593

City of Industry, CA
(626) 961-1203
Fax (626) 961-1934

Charlotte, NC
(704) 377-5134
Fax (704) 377-2649

ISO 9001

